

# A SERIES



## INDUSTRIAL GRADE POWER SWITCHES

UL, CSA LISTED  
(except 3&4 poles)

### FEATURES

- All of switch-housings cases of the standard switches are made of the approved UL standard 94V-O materials.
- Contact mechanism is designed to minimize producing noise and secure stable switching from small current to large.
- Molded-in terminals give a perfect seal against the ingress of flux at wave soldering.
- No electrical trouble will occur even if the case might be deformed during soldering process.
- The series A does comply to Japanese National Defence Standards, Japanese Industrial Standards and Electrical Apparatus Regulations and is designed to enhance its durability, humidity, corrosion, heat, cold, shock and vibration resistance.

### HOW TO ORDER

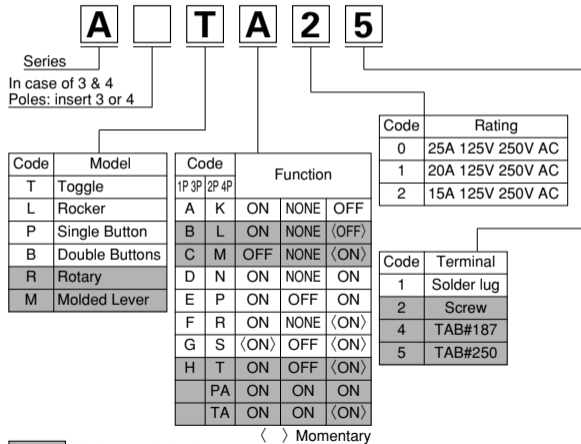



# ROTARY SELECTOR SWITCH FOR FAN COIL UNIT

(MADE TO ORDER BASIS)

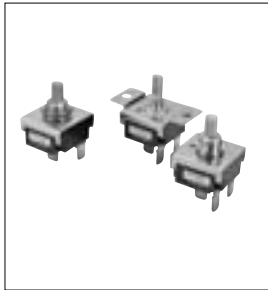

## CIRCUIT

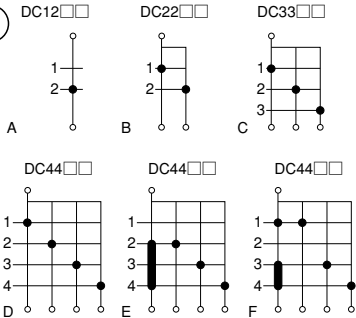

## HOW TO ORDER

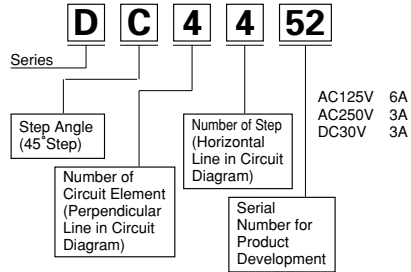

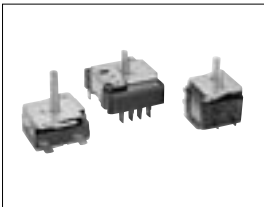

# ROTARY SELECTOR SWITCHES FOR LARGE AND MIDDLE CURRENT (MADE TO ORDER BASIS)

